

TRITEC

class 150 / 300 / 600 /
900 / 1500 /
2500

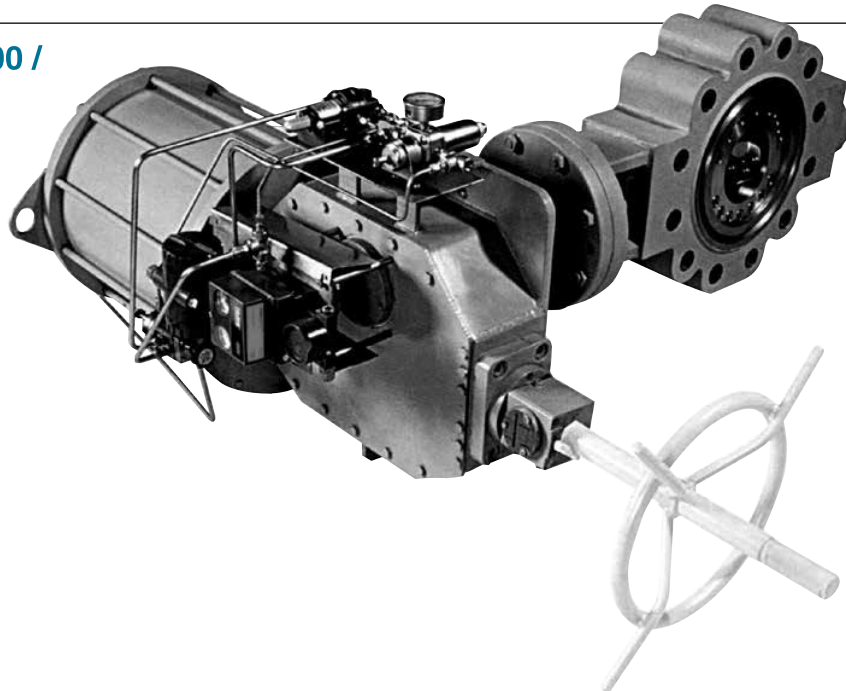

Features and Benefits

- Triple offset and ellipsoidal sealing Geometry
- Bi-directional bubble tight shut-off
- Inherently Firesafe
- Developed Geometry results in
 - Zero Seat/Seal Friction
 - Low Torques
 - Extended Service Life
 - Continued Seal through Thermal Cycling
 - Torque Seating
- Excellent flow and throttling characteristics covering services from Cryogenic to high temperature
- Excellent control of Fugitive Emission by virtue of Rotary stem movement and advanced packing materials
 - Less than 50ppm on Fugitive Emission Test to cover EPA21
 - Other tests available on request
- Firesafe meet API Std 607 4th / 5th Edition and BS 6755 part 2 / API 6FA
- Available Fully Rated to Class 2500
- Fully rated for end of line duty
- Standard materials conform to NACE, all exotic materials also available
- Laminated seat is mounted in the body, removing it from the erosive effects of the flowing media
- Seat is self centering "floating" design
- Both Seat and Seal are field replaceable without special tools
- Unique elliptical bolting pattern allows foolproof replacement of seat and seal
- Gasket Sealing Face is completely uninterrupted by fixings

- Suitable for use with Spiral Wound gaskets and all flange finishes including RTJ
- Antiblowout device on shaft with both internal and external retaining systems according to API Std 609
- ISO mounting flange allows easy fitting and changing of operators
- Operator is bolted and doweled to prevent radial movement and subsequent loss of seating torque
- Body counterbore and seat bolting arranged elliptically to ensure equal support, gasket land and gasket loading all around the elliptical edge of the laminated body seat
- Inboard and outboard thrust mechanisms prevent decentralising of disc, even under high temperature and line pressure
- By eliminating seat-seal friction on unseating, Tritec removes the "Blind Zone" and increases the rangeability or controllable range to the full 90° of movement. The rotation geometry and inboard bearing design reduce the effect of dynamic torque and mechanical noise-vibration, increasing midrange control accuracy. Cavitation and Noise reducers are available to complement the Tritec valve under high pressure drop process situations

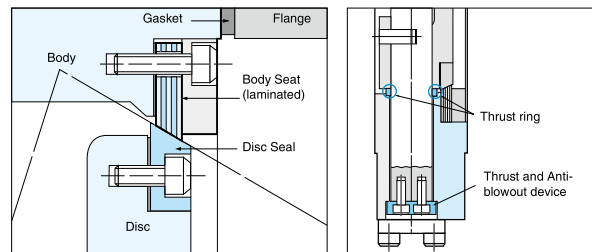

Offset Valve-Disc / Seat Friction

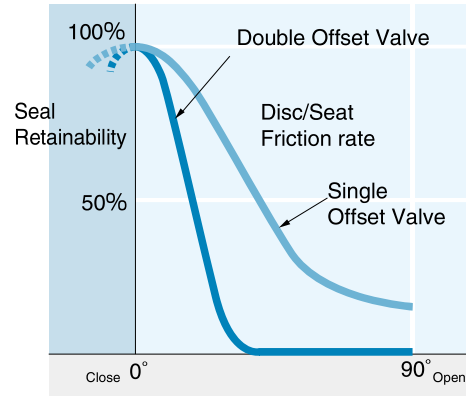
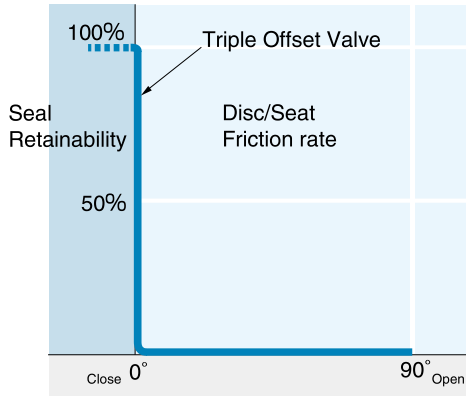

Tracing the evolution of Triple Offset design

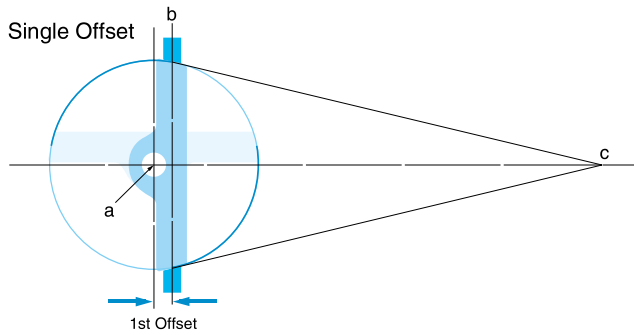

The centre of rotation is moved back from the centreline of the valve disc. The seat and seal are designed conically and on centre. This design relies on a frictional interference seal and so is applicable only to soft seated valves.

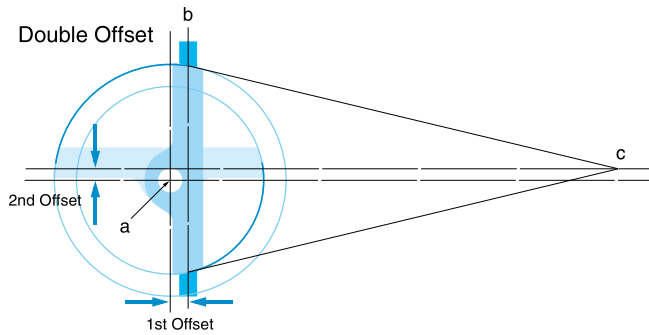

The centre of rotation is moved from the centerline of the valve body. The seat and seal design remains conical and on centre. This design again relies on a frictional interference seal, but the length of rotation over which this friction occurs is reduced, allowing a larger range of process resistant seat materials to be used. However, these materials must be relatively soft or highly elastic to prevent "jumping".

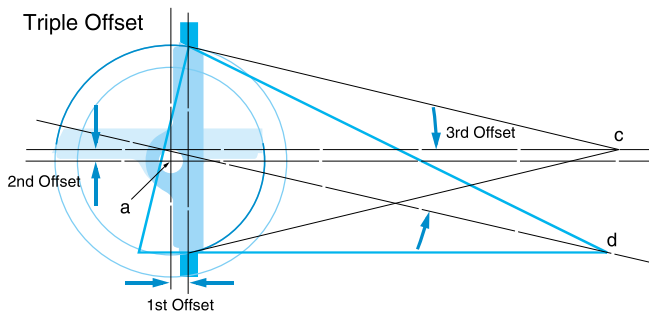

The centreline of the cone is rotated away from the valve centerline resulting in an ellipsoidal profile and providing the third offset. With this geometry, seat seal interference is completely eliminated ensuring long sealing life. The result is a torque seated, process-pressure-aided FRICTIONLESS seal. The geometry allows the body seat to be used as the closed limit stop, aiding operator adjustment. The Triple Offset design is ideally suited to metal seated valves providing bubble-tight performance in high temperature, high pressure and firesafe applications.

Butterfly Valve

TRITEC

TT2

334A

344Q

302A/303Q

304A/304Q

304YA

302Y/304Y

304M

(HLV)

507V/508V

DTM

846T/847T/847Q

841T/842T

700Z

700G/704G/705G

72WG/72SG/72LG

**731P/732P/
732Q/752W**

731R

700E/700K/700S

704G/722F/720F

227P

907T/908H

(MKT)

**903L/901C/
905C (Bata-check)**

Standard Specifications

Design	API Std 609, BS 5155, ASME B16.34, ASME SEC VIII	
Valve Sizes ^{※1}	2"(50mm) — 66"(1650mm)	
Pressure Classes	Class 150, 300, 600, 900, 1500	
Body Styles	Lugged, Wafer Flangeless, Double Flanged, Butt Weld End	
Flange Accommodation ^{※2}	ASME B16.5:DN50 — DN600 ASME B16.47 Series A&B : DN700 — DN1650	
Face to Face ^{※3} Dimensions	LUG and WAFER Type API Std 609 Table 2 : DN 80 — DN600 API Std 609 Table 1 : DN750, 900, 1050, 1200 ISO 5752 Wafer Short : DN700, 800, 1000 DOUBLE FLANGED Type ISO 5752 / BS 5155 Double Flange Short	
Pressure— Temperature Ratings	ASME B16.34 : for Steel ASME B16.24 : for Bronze Working Temperature Range as Standard —29°C (—20°F) to +538°C (1000°F) With selection of suitable materials —46°C(—51°F) to +700°C (1292°F)	
Pressure Tests	Shell Test, Seat Test : API Std 598 Seat Leakage Rate API Std 598, ISO 5208 Rate A, ASME B16.104 (ASME / FCI 70-2) Class VI	
Firesafe	Certified Firesafe to BS 6775 Part2, API 6FA and API 607 4th/5th	
Marking	API Std 609 MSS SP-25	
Operators	Manual Gear, Electric, Pneumatic, Hydraulic	
Standard materials	Body	A216 WCB, BS EN 10025 (Carbon Steel), A351 CF8M
	Disc	A216 WCB, A351 CF8M
	Stem ^{※4}	A564 type 630 H1150+1150
	Body seat	316SS / Graphite
	Disc seal ^{※5}	316SS

- ※1. Please contact the sales office for larger sizes.
 ※2. JIS 10K, 20K, 30K MSS, API, BS, DIN, PN, ISO also available on request.
 ※3. ISO 5752 Gate Valve Short (Basic series 3) on request.
 ※4. Use Inconel 718 for over 315 degrees C.
 ※5. Titanium nitride hardened, Stellite #6 Coating is available as an option.
 ※6. Please consult our sales for the service condition lower than -46°C.

Design Options

DOUBLE BLOCK & BLEED VALVES.(DBB2)

To allow verifiable, maintainable shut-off in critical isolation applications.



BUTT WELD WITH TOP ENTRY.

Allowing complete maintainability on valves which are welded into line.



DOUBLE BLOCK & BLEED VALVES COMPACT VERSION (DBB1)

One valve with a unique double seat assembly and integral bleed port.

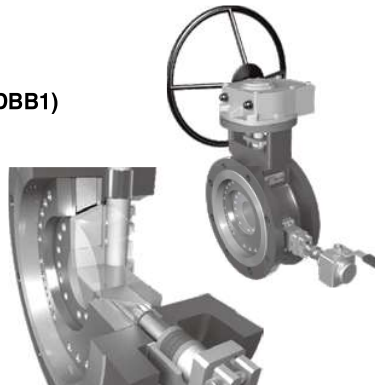

Design Options

CONTROL VALVES.

Frictionless seating means increased rangeability, allowing the Tritec valve to perform in both control and isolation application.



FIRE SAFE DESIGN.

Fire safe approval to BS 6775 Part2, API 6FA and API 607 4th/5th.



STEAM JACKETED VALVES.

To maintain process temperature ensuring media remains liquid. Disc and shaft steam tracing as an option.



Full-Jacket type



Semi-Jacket type

VALVES TO REDUCE FUGITIVE EMISSION.

Designed to reduce fugitive emission, testing is available to all international standards plus customer specific requirements.



GATE VALVE FACE TO FACE.

For the direct replacement of gate valves, all dimensions are exactly as per the standard Double Flanged valve with the exception of the face to face dimension which is shown below. (in accordance with ISO 5752 gate valve short).



(Unit: mm)

Valve Size		class 150	class 300	class 600	class 900	class 1500
mm	inch	Flanged Gate F-F	Flanged Gate F-F	Flanged Gate F-F	Flanged Gate F-F	Flanged Gate F-F
50	2	178	216	—	—	—
80	3	203	282	356	—	—
100	4	229	305	432	457	—
150	6	267	403	559	610	705
200	8	292	419	660	838	832
250	10	330	457	787	838	991
300	12	356	502	838	965	1130
350	14	381	762	889	1029	1257
400	16	406	838	991	1130	1384
450	18	432	914	1092	1219	1537
500	20	457	991	1194	1321	1664
600	24	508	1143	1397	1549	1943

Allows direct replacement of existing gate valves without modification of pipework.

Disc remains within the body face to face in the fully open position to allow removal of the valve from pipework even when the valve is open.

Reduction of fugitive emission due to quarter turn rather than linear shaft movement.

Reduced operator costs due to quarter turn rather than multi turn / linear.

Referential Drawing

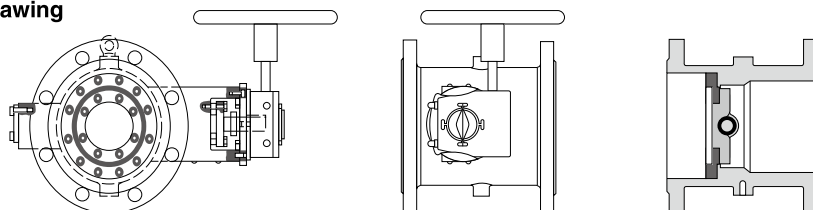

Butterfly Valve
TRITEC
TT2
334A
344Q
302A/303Q
304A/304Q
304YA
302Y/304Y
304M (HLV)
507V/508V
DTM
846T/847T/847Q
841T/842T
700Z
700G/704G/705G
72WG/72SG/72LG
731P/732P/732Q/752W
731R
700E/700K/700S
704G/722F/720F
227P
907T/908H (MKT)
903L/901C/905C (Bata-check)

Pressure-Temperature Ratings

Body A216 Gr. WCB
 Disc A216 Gr. WCB
 Shaft A564 Type 630

Body A351 Gr. CF8M
 Disc A351 Gr. CF8M
 Shaft A564 Type 630

Temperature		Working Pressure (MPa)				
(°F)	(°C)	150	300	600	900	1500
-20	-29	1.96	5.11	10.2	15.3	25.5
100	38	1.96	5.11	10.2	15.3	25.5
122	50	1.92	5.01	10.0	15.0	25.1
212	100	1.77	4.66	9.32	14.0	23.3
302	150	1.58	4.51	9.02	13.5	22.5
392	200	1.38	4.38	8.76	13.1	21.9
482	250	1.21	4.19	8.39	12.6	21.0
572	300	1.02	3.98	7.96	12.0	19.9
617	325	0.930	3.87	7.74	11.6	19.4
662	350	0.840	3.76	7.51	11.3	18.8
707	375	0.740	3.64	7.27	10.9	18.2
752	400	0.650	3.47	6.94	10.4	17.4
797	425	0.550	2.88	5.75	8.63	14.4
842	450	0.460 ^{*1}	2.30 ^{*1}	4.60	6.90	11.5
887	475	0.370 ^{*1}	1.74 ^{*1}	3.49	5.23	8.72
932	500	0.280 ^{*1}	1.18 ^{*1}	2.35	3.53	5.88
1000	538	0.140 ^{*1}	0.590 ^{*1}	1.18	1.77	2.95

Temperature		Working Pressure (MPa)				
(°F)	(°C)	150	300	600	900	1500
-20	-29	1.90	4.96	9.93	14.9	24.8
100	38	1.90	4.96	9.93	14.9	24.8
122	50	1.84	4.81	9.62	14.4	24.1
212	100	1.62	4.22	8.44	12.7	21.1
302	150	1.48	3.85	7.70	11.6	19.3
392	200	1.37	3.57	7.13	10.7	17.8
482	250	1.21	3.34	6.68	10.0	16.7
572	300	1.02	3.16	6.32	9.49	15.8
617	325	0.930	3.09	6.18	9.27	15.4
662	350	0.840	3.03	6.07	9.10	15.2
707	375	0.740	2.99	5.98	8.96	14.9
752	400	0.650	2.94	5.89	8.83	14.7
797	425	0.550	2.91	5.83	8.74	14.6
842	450	0.460	2.88	5.77	8.65	14.4
887	475	0.370	2.87	5.73	8.60	14.3
932	500	0.280	2.82	5.65	8.47	14.1
1000	538	0.140	2.52	5.00	7.52	12.6

(Notes) *1. Permissible, but not recommended for prolonged use above 800°F(427 degree C).
 Please contact a sales office for temperatures outside of standard temperature range as detailed in the above table.

Pressure-Temperature Ratings (ASME B 16.34-2004)

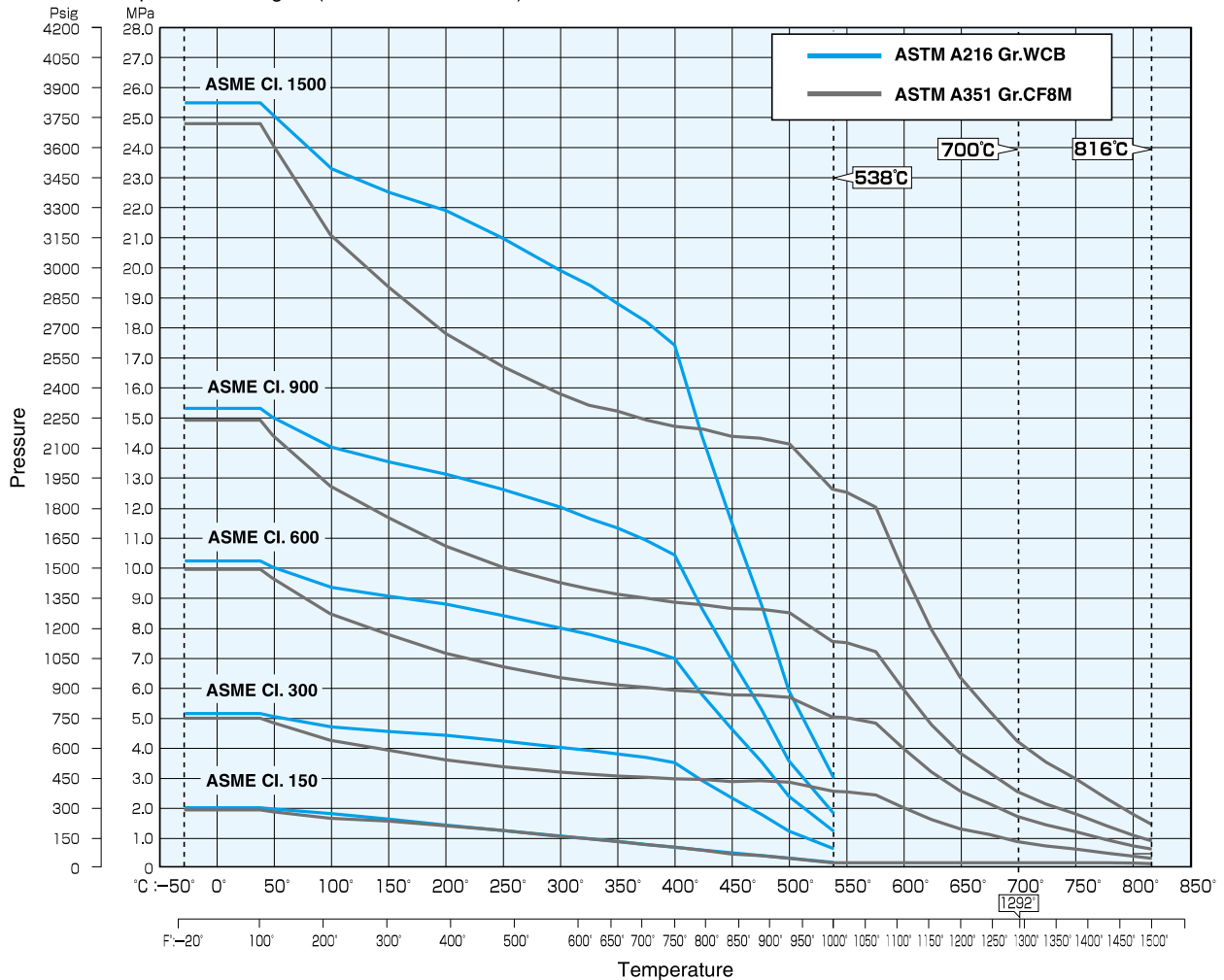

Allowable Seat Leakage Rates by Standard

Gas Test

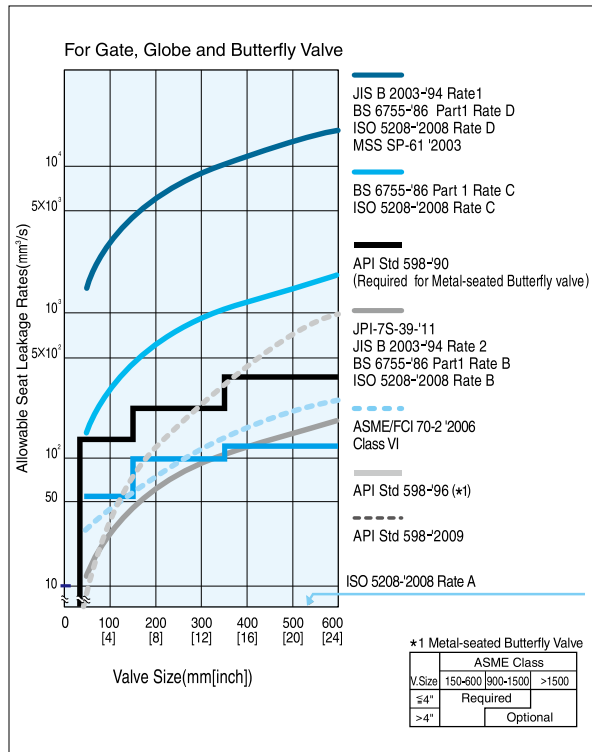

Hydrostatic Test

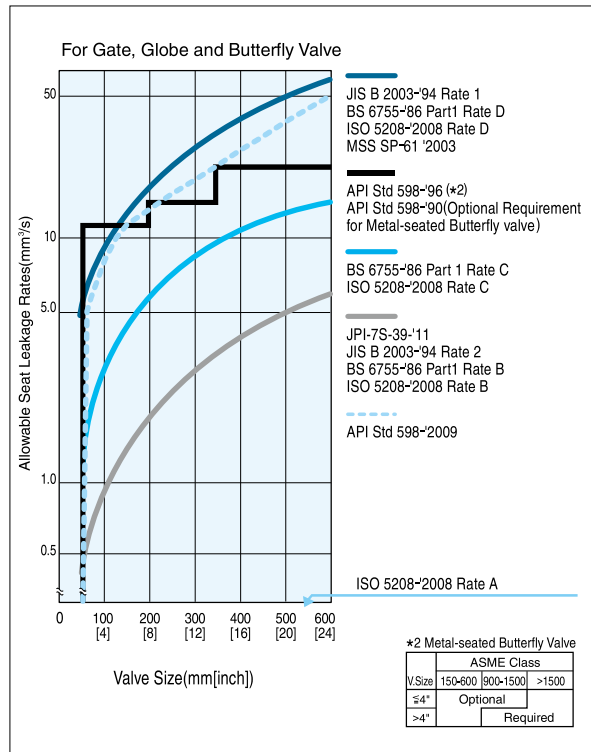

Allowable Seat Leakage Rates by Standard

Gas Test

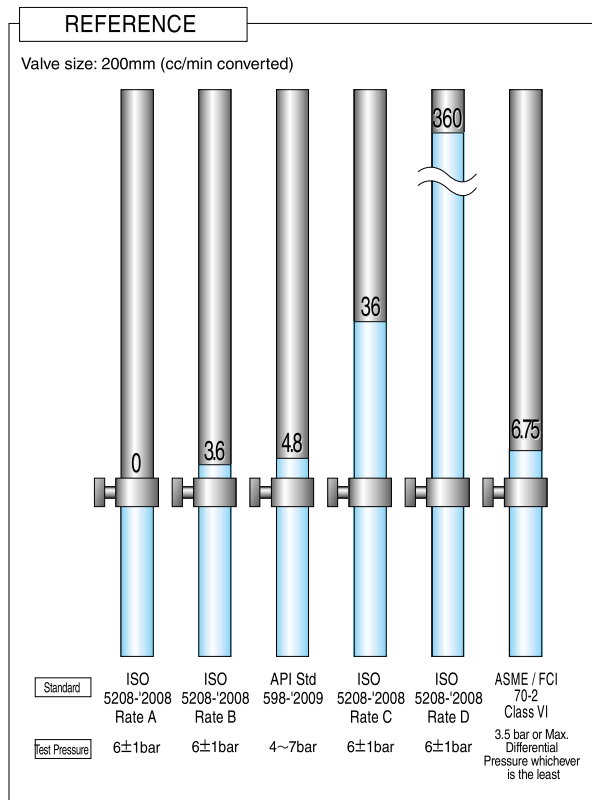

Hydrostatic Test

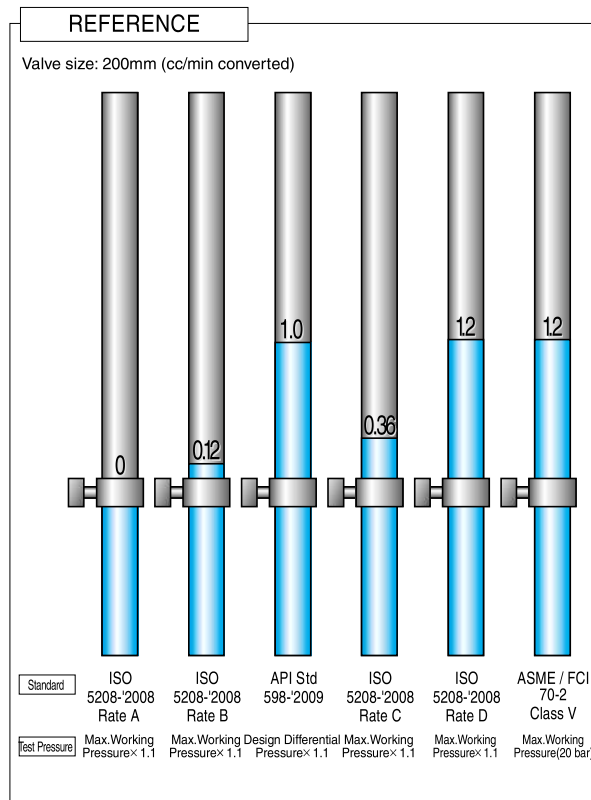

Butterfly Valve

TRITEC

TT2

334A

344Q

302A/303Q

304A/304Q

304YA

302Y/304Y

304M (HLV)

507V/508V

DTM

846T/847T/847Q

841T/842T

700Z

700G/704G/705G

72WG/72SG/72LG

731P/732P/732Q/752W

731R

700E/700K/700S

704G/722F/720F

227P

907T/908H (MKT)

903L/901C/905C (Bata-check)

Operating and Maintenance Instructions

No	Description	Q'ty
1	Body	1
2	Disc	1
★ 3	Body Seat	1
4	Body Seat Retaining Ring	1
★ 5	Body Seat Gasket	1
6	Disc Seal	1
7	Disc Seal Gasket	1
8	Shaft	1
9	Shaft pin	2-4
10	Bearing	4
11	Thrust Ring	2
13	End Cover	1
14	End Cover Gasket	1
15	Gland Plate	1
16	Gland Plate Spigot	1

No	Description	Q'ty
17	Mounting Plate	1
18	Dowel Pin	2-4
19	Nameplate	1-2
22	Disc Seal Screw	1 set
24	Body Seat Screw	1 set
25	Mounting Plate Screw	4-6
26	End Cover Screw	4
27	Gland Stud	2
29	Gland Nut	2
33	Gland Packing	3
★ 34	Gland Packing	2
★ 35	Key	1
37	Anti-blowout Collar	1
38	Anti-blowout Device	1-2

★ : Recommended Spare Parts

⊙ : Please refer to specific drawings

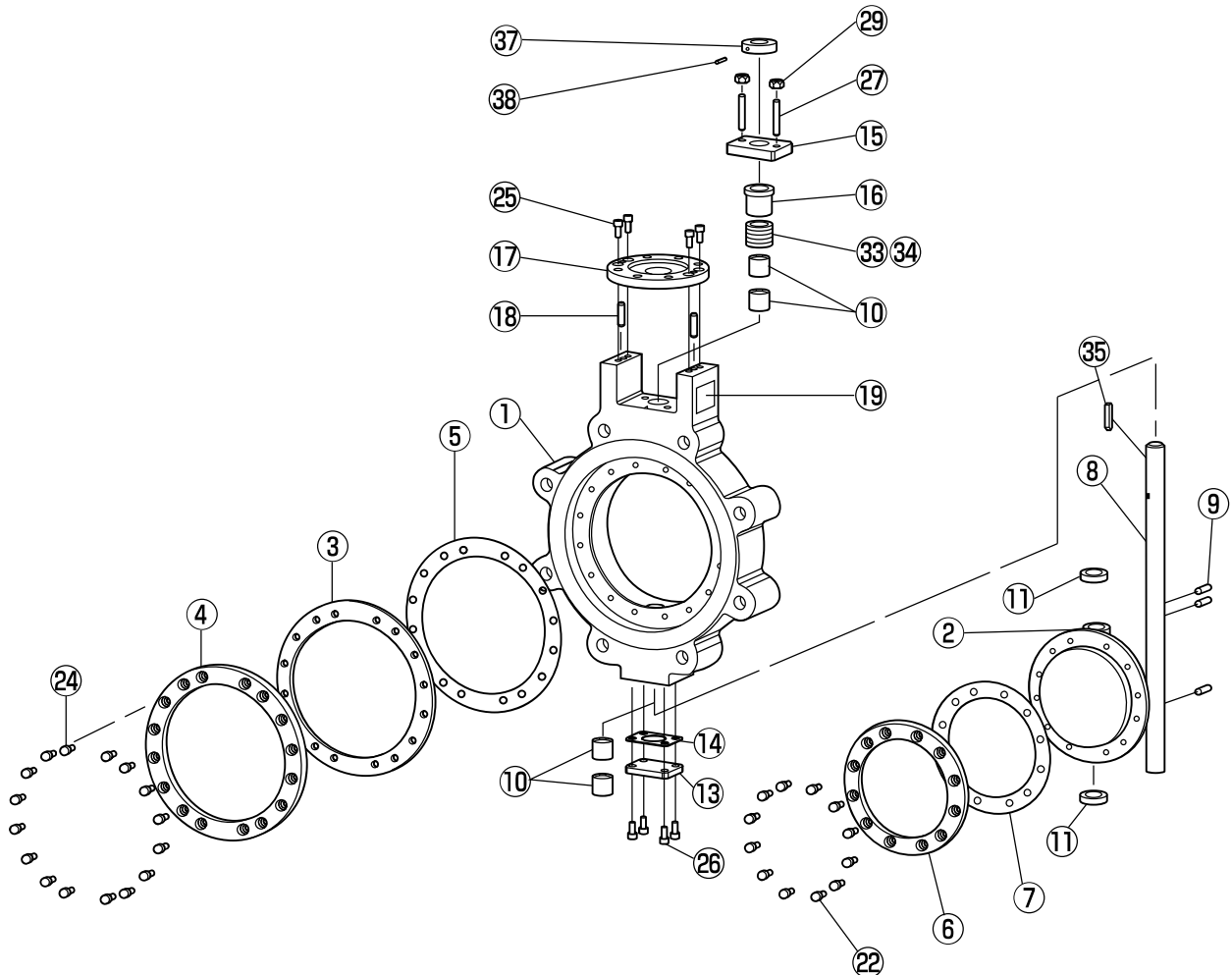

Operating and Maintenance Instructions

INTRODUCTION

This instruction provides general information on the operation, installation and maintenance of the Tritec triple offset valve. The Tritec valves have been designed and manufactured to operate in an aggressive environment under extremes of temperature and pressure for long periods and with minimal maintenance.

INSTRUCTIONS

PACKING

1. All valves will be despatched with protective covers attached to the flange faces to protect the gasket sealing surfaces and internal trim.
2. The valve disc is cracked off the seat in the almost closed position.
3. The Tritec nameplate shown in the picture contains information such as size, pressure class, materials and the unique serial number.

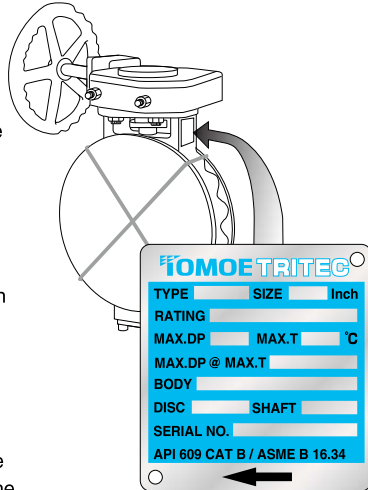

SPARE PARTS

1. When ordering spare parts or discussing matters concerning this valve with the sales office, it is essential to quote the unique Serial Number of the valve which is to be found on the stainless steel nameplate attached to the valve body adjacent to the operator.

TRANSPORTATION

1. Use crates or packing cases for ocean transportation.
2. For overland transportation, a covered vehicle is recommended with protective sheets covering the valves.

STORAGE

1. Store the valves indoors in a cool temperature between -10° and $+60^{\circ}\text{C}$, humidity at 70% or less.
2. Do not remove the protective covers until ready to install valves.
3. Machined ferrous surfaces are protected with an approved rust preventative. For long periods of storage, apply the rust preventative once a year to the unpainted surfaces.
4. When storing valves unpacked, take care in protecting valves and actuators from excessive loads. Do not stack unpacked valves.
5. If the valve is for clean gas duty and is being supplied "DEGREASED", a label is attached stating this and the valve sealed in a polythene covering. It is suggested that the valve is kept packed until it is to be installed in the pipeline.

UNPACKING

1. Unpack valves just before installation.

INSTALLATION

- Ⓐ The valve is designed to seal against bidirectional flow and can therefore be installed with flow in either direction. However enhanced sealing life will be obtained with upstream flow against the shaft side of the disc. This preferred flow direction is shown on the nameplate attached to the valve body adjacent to the operator and also on the GA drawing. The valve may be installed in the pipeline with the valve shaft in a horizontal, vertical or intermediate position.
- Ⓑ Prior to installation, the pipeline must be cleaned from dirt and welding residues to avoid damage to the valve during operation.
- Ⓒ Ensure that the valve is closed prior to installation to avoid the risk of damage to the sealing surfaces.
- Ⓓ The valve must be lifted by the eyebolt or lifting eyes provided with the valve.
- Ⓔ The valve must not be lifted by the operator or handwheel.
- Ⓕ The valve must not be used for pipework alignment.
- Ⓖ The Lugged or Double flanged type valve is suitable for dead end service i.e. end of line duty, in either direction (in case of the valve specified both directions) to the full rating pressure of the piping system.

Butterfly Valve

TRITEC

TT2

334A

344Q

302A/303Q

304A/304Q

304YA

302Y/304Y

304M

(HLV)

507V/508V

DTM

846T/847T/847Q

841T/842T

700Z

700G/704G/705G

72WG/72SG/72LG

731P/732P/

732Q/752W

731R

700E/700K/700S

704G/722F/720F

227P

907T/908H

(MKT)

903L/901C/

905C (Bata-check)